



STAS SERIES SELECTRONIC® ALARM ANNUNCIATORS

DESIGN, INSTALLATION AND OPERATING MANUAL



CALL MURCAL TO PLACE YOUR ORDER



P:(661)272-4700 F:(661)947-7570
www.murcal.com e-mail:sales@murcal.com



Certain danger to human safety and to equipment may occur if some equipment is stopped without pre-warning. It is recommended that monitored functions be limited to alarm-only or to alarm before shutdown.

WARNING

BEFORE BEGINNING INSTALLATION OF THIS MURPHY PRODUCT

- ✓ Disconnect all electrical power to the machine.
- ✓ Make sure the machine cannot operate during installation.
- ✓ Follow all safety warnings of the machine manufacturer.
- ✓ Read and follow instructions.

Table of Contents

Section I: Introduction	1
Section II: Specifications	1
Section III: Standard Features	2
Section IV: Installation Operation	2
Figures:	
Figure 1: Switch wiring for STAS series	2
Figure 1a: ST5AS and ST10AS	
Typical LED Display and Label Sheet Information	3
Figure 2: ST5AS Circuit Diagram	4
Figure 3: ST10AS Circuit Diagram	4
Figure 4: ST5DAS Circuit Diagram	5
Figure 5: ST5AS-F Mechanical Installation	6
Figure 6: ST10AS-F and ST5DAS-F Mechanical Installation	6
Figure 7: Gimbal Mounting Dimensions	7
Figure 9: TDST 3-5 and TDST 8-10 Mechanical Installation	7
Figure 10: Diode Package Wiring Diagram	8
Figure 11: TDST 3-5 and TDST 8-10 Wiring Diagram	8

Warranty

A limited warranty on materials and workmanship is given with this FWMurphy product.
A copy of the warranty may be viewed or printed by going to www.fwmurphy.com/warranty.asp.

MURPHY

CALL MURCAL TO PLACE YOUR ORDER

murCal

P:(661)272-4700 F:(661)947-7570
www.murcal.com e-mail: sales@murcal.com



Section I: Introduction



CAUTION: Certain dangers to human safety and to equipment may occur if some equipment is stopped without pre-warning. It is recommended that monitored functions be limited to alarm-only or to alarm before shutdown.

- A. This manual is directed to the design, installation, and operation of alarm systems using the STAS family of alarm annunciators and accessories.
- B. The Murphy STAS family of alarm annunciators are designed to indicate the cause of an alarm with both an audio and visual signal. The audible portion of the warning has an alarm silence so the operator can turn off the alarm, but leave the flashing warning light on. A selectable lockout time delay is provided so that when power is applied the audible alarm does not operate and the circuit does not latch on. This feature gives the monitored variables of an engine time to reach their desired normal levels. The built-in lockout time delay feature may be bypassed by the user, see Section IV: Installation Operation "A" Electrical #1, #2 and #3.

Another feature is that a momentary alarm contact will register and lock in until the Alarm Silence/Lamp Test button is operated. Remote Silence feature can be wired for all models, see Figures 2 and 3 Typical Circuit Diagrams(p-4).

- C. The ST5AS model is a five-function alarm annunciator with an Alarm Silence/Lamp Test button. The ST10AS model is a ten-function alarm annunciator with the Alarm Silence/Lamp Test button. The ST5DAS model consists of two ST5AS's in one package with separate positive power supplies and a common negative. The ST5DAS has a common alarm and Alarm Silence/Lamp Test button. The ST5DAS is a convenient device for monitoring two separate engines within the same package. The three different types of mounting for the ST5AS, ST10AS, and ST5DAS families are listed below.

DESIGNATION	MOUNTING
LM	Less Mounting
F	Flush mount bezel
G	A rotating Gimbal is provided as a mounting device

Auxiliary devices designed to be used with the STAS electronic TATTLETALE® family include the TDST 3-5 and TDST 8-10 .

1. When two or more STAS Selectronic Tattletales are wired together (Example: Pilot house and fly bridge) customer supplied diodes must be installed between each Tattletale to protect the circuitry in each device from the feed back voltage from the other devices.
2. TDST 3-5 Time Delay. A single point 3-5 second delay. The TDST 3-5 is commonly used to delay bilge alarm signals to compensate for roll and pitch of marine vessels.
3. TDST 8-10 Time Delay. A single point 8-10 second delay.

Section II: Specifications

A. STAS Family

1. Power Requirements

- a. Voltage 8-30 VAC, 8-40 VDC
- b. Current
 - i. Standby 10 mA
 - ii. 1 LED flashing 40 mA @ 12 VDC
 - iii. 1 LED flashing 50 mA @ 40 VDC

2. Input Requirements

Dry contact switches either normally open or normally closed.

3. Output

Remote Alarm Relay: customer supplied, same as input voltage, coil not to exceed 500 mA.

4. Temperature Range

-4°F to 158°F (-20°C to 70°C)

5. Enclosure

Black ABS Plastic

B. TDST 3-5 and TDST 8-10

(Only operate with N.O. circuit that close to alarm)

1. Power Requirements

- a. Voltage 8-30 VDC
- b. Current
 - i. Operating 5 mA
 - ii. Output sink 100 mA @ 24 V maximum

2. Temperature Range

-4°F to 158°F (-20°C to 70°C)

3. Enclosure

Black ABS Plastic

Section III: Standard Features

- A. The STAS family of alarm annunciators include the following standard features.
 1. MINI-SIREN® audio alarm
 2. Alarm silence function that turns the MINI-SIREN® off but leaves the LED alarm flashing. Additional alarms also sound the MINI-SIREN® even if it has been silenced.
 3. Audio alarm lockout time delay at start up (power on): 25 to 35 seconds (may be bypassed by the customer, see Section IV below; "A" Electrical #1, 2, 3).
 4. The mounting options include less mounting (LM), flush mounting (F), and gimbal mounting (G).
 5. Alarm relay driver for customer supplied relay (24 V maximum, coil not to exceed 500 mA). Relay voltage same as input.
 6. Lamp Test Function lights Alarm LED's while depressed.
- B. The ST5AS has a five-point LED alarm with generic function labels for each.
- C. The ST10AS has a ten-point LED alarm with generic function labels for each.
- D. The ST5DAS has two five-point LED alarms with generic function labels for each. The ST5DAS has a common connection for the MINI-SIREN®, Alarm Silence/Lamp Test function, and negative for the power supplies. Two remote alarm relay outputs are provided. Although it uses two separate positive voltage inputs, the negative must be common to each power supply.

Section IV: Installation Operation

A. Electrical—Typical customer switch wiring for the STAS family of alarm annunciators at terminals A and B are shown in Figure 1. Switch wiring should be run separate from other wires; DO NOT run along with AC power wires since voltages, that may be induced into the switch wires, may exceed rating and cause damage to circuits.

Specific circuit diagrams for the ST5AS, ST10AS, and ST5DAS are listed in Figure 1 below. Figure 1A shows the wiring for a normally closed switch connected to input terminals A and B. The factory supplied metal link must be removed to use this wiring. When the switch opens the alarm will sound.

Figure 1B shows the wiring for a normally open switch con-

Figure 1

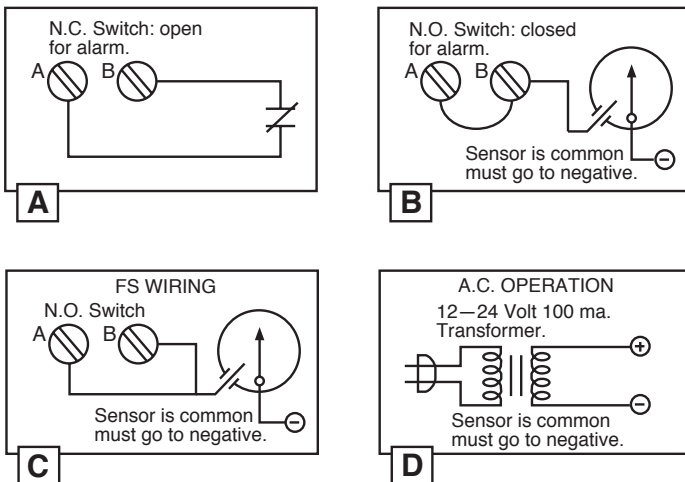

ected between terminal B and the negative power input. The metal link is connected between A and B. When the switch closes the alarm circuit turns on.

Figure 1C shows the wiring for a normally open switch which is the same as Figure 1B except two wires are run from the STAS Terminal A and B to the switch. With this closed loop wiring the circuit monitors the wires as well as the switch. If the circuit is opened due to a loose connection or broken wire, the alarm will sound. Anytime the normally open switch is closed to the negative side of the power supply the alarm sounds.

Figure 1D shows how to wire a small control transformer to supply AC power to the STAS family. If an alarm relay is used, the relay coil should be the same voltage as the transformer secondary, but it must be a DC coil. An AC coil relay will not work. Wire alarm relay as shown in Figures 2 & 3 (p. 4).

1. The ST5AS circuit diagram is shown in Figure 2 (p. 4). This figure shows the STAS monitoring one engine. Alarm system is turned on with a manual ON/OFF switch. An alarm relay is provided to sound a remote alarm bell. Start-up time delay is bypassed with a jumper from #2 to #5.
2. The ST10AS circuit diagram is shown in Figure 3 (p. 4). This figure shows the ST10AS used to monitor two generator engines and four bilge levels. The common connections of the engine SWICHGAGE® instruments are wired through a fuel pressure switch so the alarm switches are disconnected while the engine is not running. The four bilge switches are active at all times. The start-up time

delay is bypassed with a jumper from #16 to #12. An alarm relay, if used, is wired to #13 and #15.

3. The ST5DAS circuit diagram is shown in Figure 4 (p. 5). This figure shows the ST5DAS monitoring two main engines. The ON/OFF switches may be either manually operated or could be speed or fuel pressure switches, which would turn on the alarm system when the engine is started. The start-up time delay is used to prevent normal start-up alarms (Start-up time delay is bypassed with a jumper from #2 to #5.) The negative of power supplies must be common.

Note: When power is removed or to reset the equipment, wait 5-10 seconds before applying power again to allow the internal components to stabilize.

B. Mechanical—Specific types of installation for ST5AS, ST10AS, and ST5DAS with “F” and “G” options are listed below.

1. The mechanical installation for the ST5AS-F is shown in Figure 5 (p. 6). The mechanical installations for the ST10AS-F and ST-DASF are shown in Figure 6 (p. 6). Four screws, 6-32 x 5/8 in. (supplied), are used on the flush mount bezel to connect it to a mounting panel or dash.
2. The mechanical installation for the “G” option on the ST5AS, ST10AS, and ST5DAS is shown in Figure 7 (p. 7). Three holes are provided in the base of the Gimbal for installation.
3. The mounting of the TDST 3-5 and TDST 8-10 is shown in Figure 9 (p. 7). Two #8 screws can be used to attach a TDST to a mounting panel or dash.

C. Directions for Application of Preprinted Alarm Labels—

If you have received labels with the unit and you wish to apply these labels in certain designations follow these steps to insure a proper application:

1. Be sure face is clean and free of oil.
2. Peel one label at a time and position on the ST unit.
3. Before pressing down, be sure label is correct.
4. Rub down firmly, and leave untouched for several hours.

The pressure sensitive labels are permanent when properly applied.

D. Auxiliary Installation—A description of the installation for the TDST 3-5 and TDST 8-10 Time Delay, is the following:

1. TDST 3-5 is used when a 3-5 second time delay is needed. A typical wiring diagram for the TDST 3-5 and TDST 8-10, with the STAS family, are shown in Figure 11 (p. 8).
2. TDST 8-10 is used when a 8-10 second time delay is needed. The wiring diagram is the same as the TDST 3-5 in Figure 11.

CALL MURCAL TO PLACE YOUR ORDER



P:(661)272-4700 F:(661)947-7570

www.murcal.com e-mail:sales@murcal.com

Figure 1a: ST5AS and ST10AS Typical LED display and label sheet information

ST10AS-F Terminal Designations

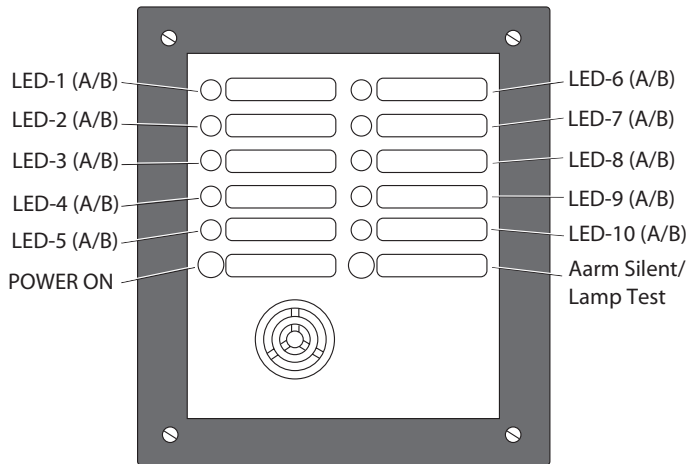

ST5AS-F Terminal Designations

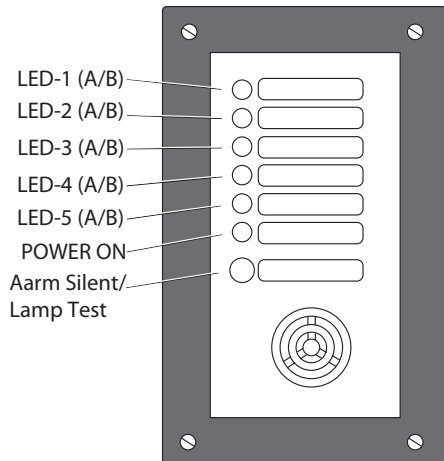

Label Sheet List

The following list of labels is supplied with the unit. Select the needed labels and follow the directions for the application of the labels. (See C. above).

Note: These labels are permanent, precut and pressure sensitive.

Label sheet list

- AFTERCOOLER TEMPERATURE
- AFTERCOOLER WATER LEVEL
- AIR FILTER
- AIR PRESSURE
- BEARING PRESSURE
- BEARING TEMPERATURE
- BILGE LEVEL
- CLUTCH AIR PRESSURE
- DAY TANK #1
- DAY TANK #2
- DAY TANK #3
- DAY TANK #4
- ENGINE OIL PRESSURE
- ENGINE OIL TEMPERATURE
- ENGINE ROOM TEMPERATURE
- ENGINE WATER LEVEL
- ENGINE WATER PRESSURE
- ENGINE WATER TEMPERATURE
- EXHAUST TEMPERATURE
- FIRE ALARM
- FUEL FILTER
- FUEL LEVEL
- FUEL PRESSURE
- FUEL RESTRICTION
- FUEL SEPARATOR WATER LEVEL
- GEAR OIL PRESSURE
- GEAR OIL TEMPERATURE
- GENERATOR OIL PRESSURE
- GENERATOR WATER TEMP.
- GENERATOR #1 OIL PRESSURE
- GENERATOR #1 WATER TEMP.
- GENERATOR #1 WATER LEVEL
- GENERATOR #2 OIL PRESS.
- GENERATOR #2 WATER TEMP.
- GENERATOR #2 WATER LEVEL
- HYDRAULIC LEVEL
- LOW VOLTAGE
- MANIFOLD BOOST
- MANIFOLD TEMPERATURE
- OVERSPEED
- PORT
- PORT GENERATOR ENGINE
- PORT MAIN ENGINE
- PORT OIL PRESSURE
- PORT WATER TEMPERATURE
- PORT OIL TEMPERATURE
- PORT WATER LEVEL
- PORT WATER PRESSURE
- RAW WATER PRESSURE
- STARBOARD
- STARBOARD GENER. ENGINE
- STARBOARD MAIN ENGINE
- STARBOARD OIL PRESSURE
- STARBOARD WATER TEMP.
- BILGE LEVEL
- STARBOARD OIL TEMPERATURE
- STARBOARD WATER LEVEL
- STARBOARD WATER PRESSURE
- TRANSMISSION OIL FILTER
- TRANSMISSION PRESSURE
- TRANSMISSION TEMPERATURE
- OIL PRESSURE/LEVEL
- WATER PRESSURE/LEVEL

Figure 2: ST5AS Typical Circuit Diagram

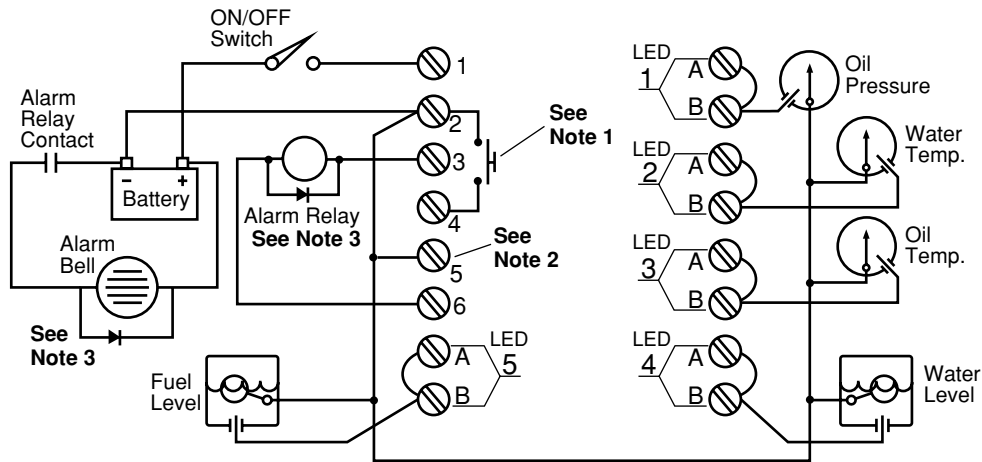

- NOTE 1:** External Alarm Silence (no Lamp Test).
- NOTE 2:** Jumper to ground to bypass Lockout Time Delay on Startup.
- NOTE 3:** Place Reverse Bias Diodes across inductive loads.

Figure 3: ST10AS Typical Circuit Diagram

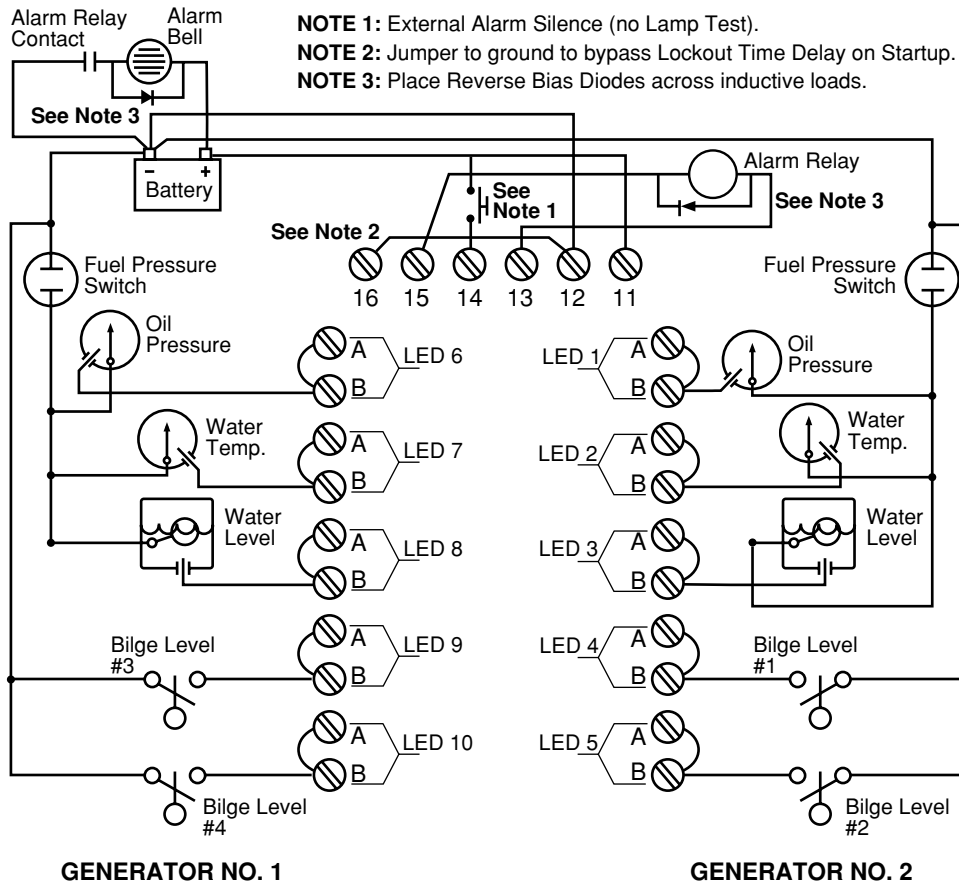

- NOTE 1:** External Alarm Silence (no Lamp Test).
- NOTE 2:** Jumper to ground to bypass Lockout Time Delay on Startup.
- NOTE 3:** Place Reverse Bias Diodes across inductive loads.

GENERATOR NO. 1

GENERATOR NO. 2

Figure 4: ST5DAS Typical Circuit Diagram

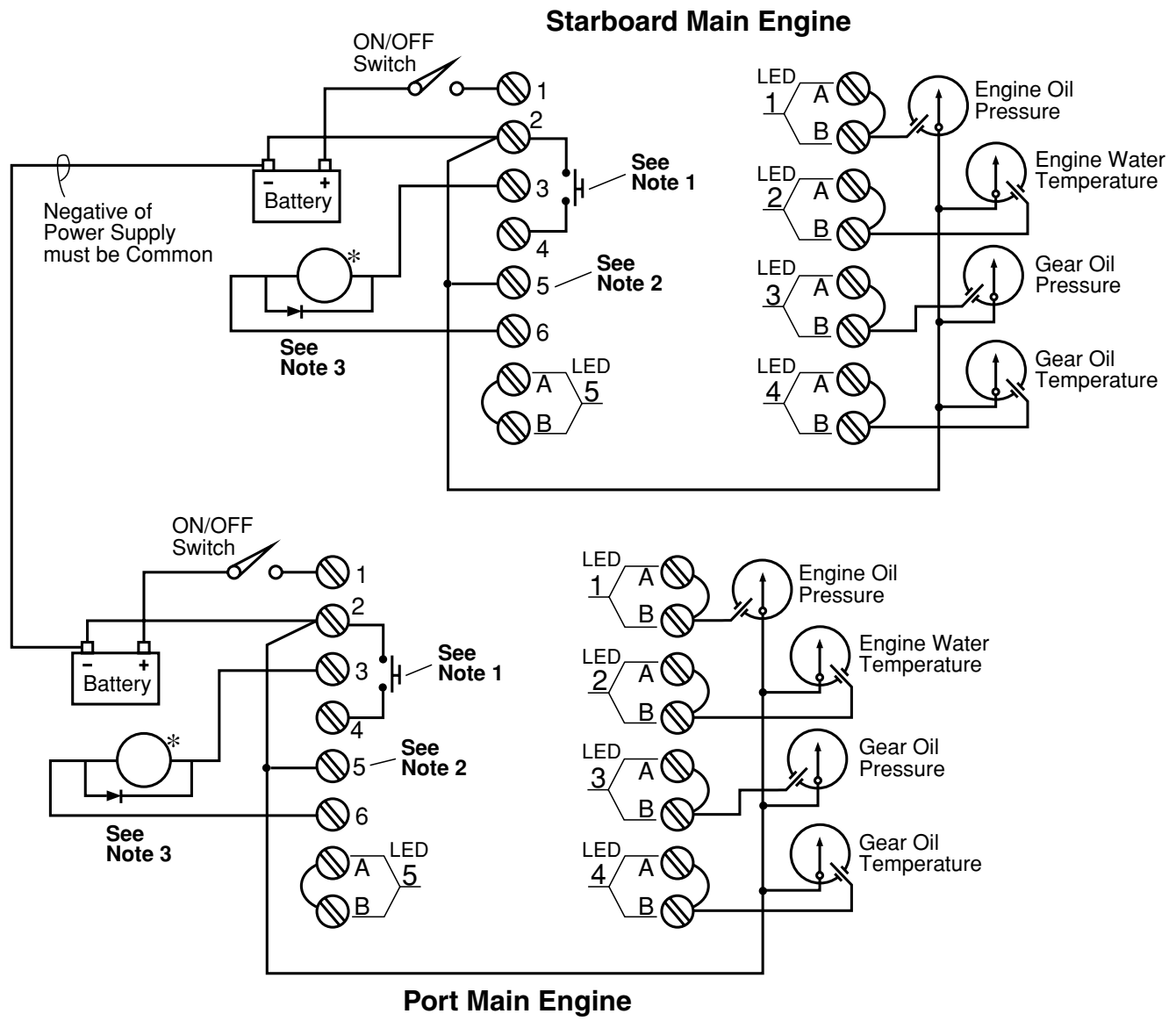

- NOTE 1:** External Alarm Silence (no Lamp Test).
 - NOTE 2:** Jumper to ground to bypass Lockout Time Delay on Startup.
 - NOTE 3:** Place Reverse Bias Diodes across inductive loads.
- * Alarm Relay if used

Figure 5: ST5AS-F Mechanical Installation

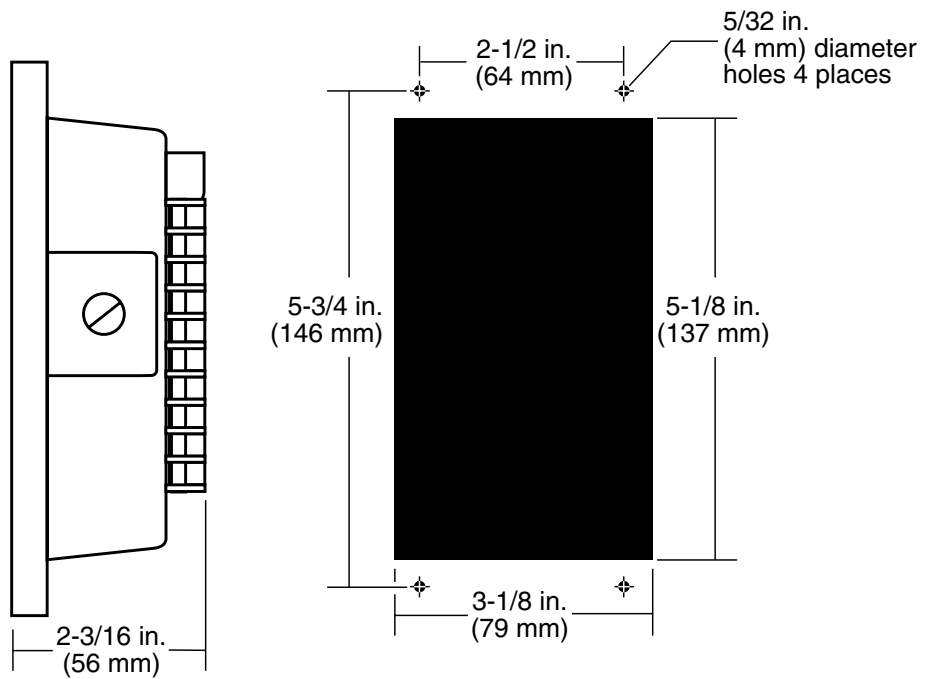
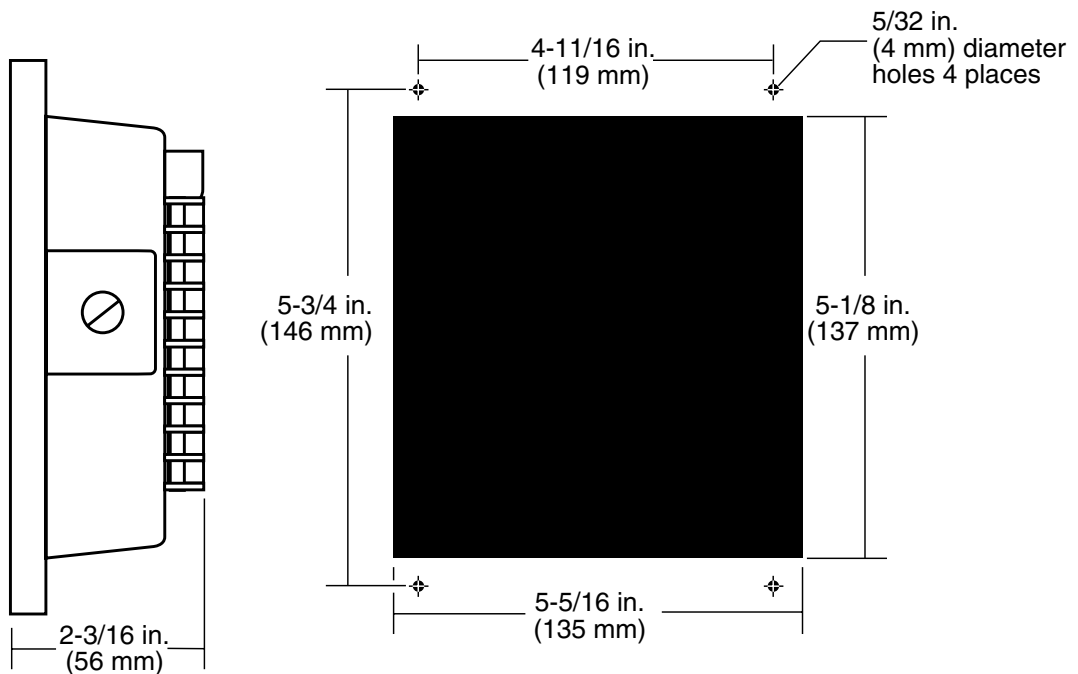

Figure 6: ST10AS-F and ST5DAS-F Mechanical Installation



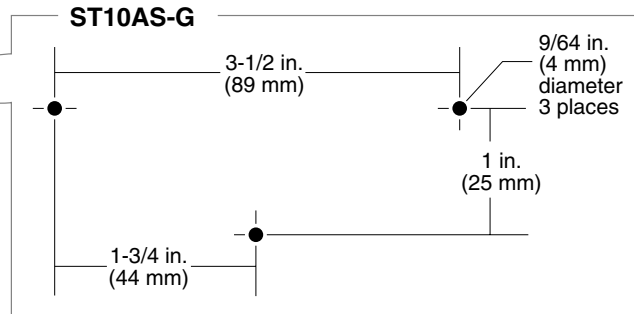
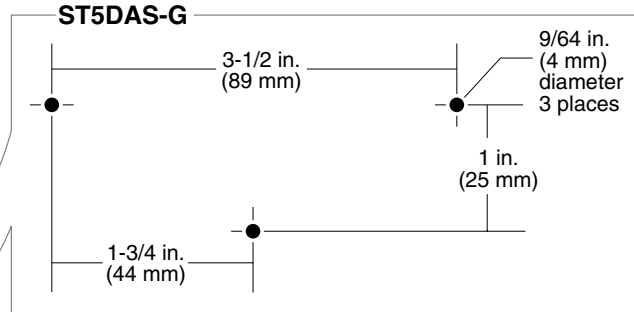
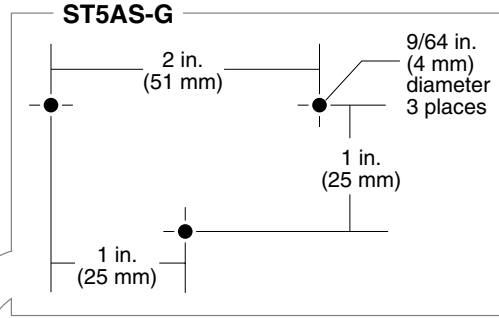
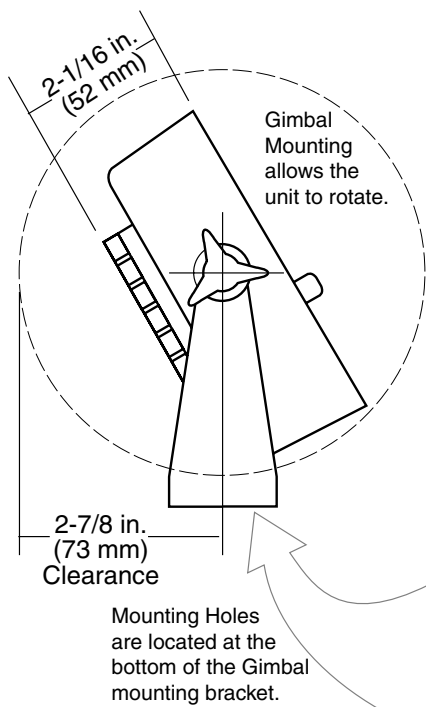

Figure 7: Gimbal Mounting Dimensions

Figure 9: TDST 3-5 and TDST 8-10 Mechanical Installation

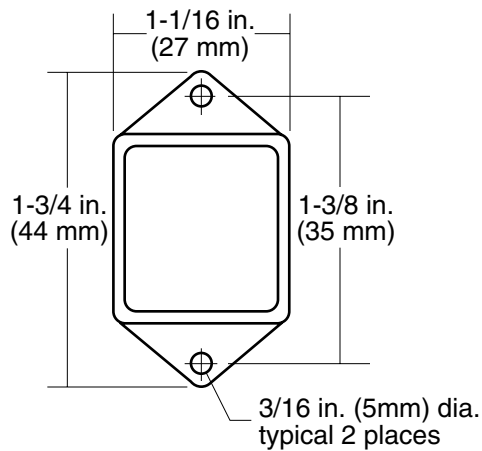

Figure 10: Customer Supplied Diode Package Wiring Diagram

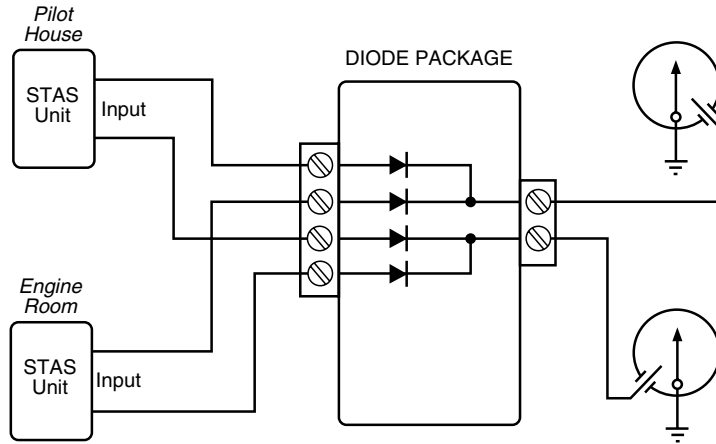

Figure 11: TDST 3-5 and TDST 8-10 Wiring Diagram

CAUTION: It is suggested that unused wires (noted as "No Connection") be cut off close to the case. This will prevent interference with normal operation.

