

# Exhaust Pyrometers Installation Instructions for Models: 10705146 (00-00-0819) and 10705147 (00-00-0956)



Please read the following information before installing. A visual inspection of this product for damage during shipping is recommended before mounting. It is your responsibility to have a qualified person install this unit and make sure it conforms to local codes.

## GENERAL INFORMATION

WARNING

BEFORE BEGINNING INSTALLATION OF THIS MURPHY PRODUCT

- ✓ Disconnect all electrical power to the machine.
- ✓ Make sure the machine cannot operate during installation.
- ✓ Follow all safety warnings of the machine manufacturer.
- ✓ Read and follow all installation instructions.



These Murphy analog pyrometers do not require power. NEVER apply vehicle voltage to pyrometer terminals, damage beyond repair will occur. Only the illuminating lamp requires voltage.

### Description

The single port 10705147 (00-00-0956) and the dual port 10-705146 (00-00-0819) analog pyrometers monitor exhaust temperatures in all types of engines. The Dual Port Pyrometer can monitor each bank of a V-type engine, allowing you to compare readings at all times. Both pyrometers feature an easy-to-read illuminated dial with scales in both Fahrenheit and Celsius. They require no outside power (except for dial lighting). Spring loaded jewels and alloy pivots increase durability. Murphy offers pyrometer accessories such as thermocouples and wire harnesses.

### Application

Excessive exhaust temperature is a major damaging factor to all engines. The best way to monitor this temperature is with the use of a pyrometer. Excessive exhaust temperature is caused by an upset fuel/air ratio or more fuel in the engine than there is air to support it. This condition can occur as a result of over throttling, a dirty air cleaner, different fuels, a malfunctioning fuel system, change of altitude, an out of tune engine and many other causes. But whatever the cause, a pyrometer indicates this condition before serious damage occurs.

Suitable for stationary or mobile engines, power units, agricultural and construction equipment, as well as marine and trucking.

### Specifications

**Dial Scale:** Single: 300 to 1300°F (150 to 700°C)  
 Dual: 300 to 1200°F (150 to 649°C)

**Dial Sweep (both models):** 100°.

**Accuracy:** Full scale 2%.

**Illumination:** Internal 12 or 24 VDC (specify).

**Bezel:** Polished stainless steel.

**Case:** PVC.

**Pointer(s):** Fire Orange.

### Dimensions

10705146 (00-00-0819)

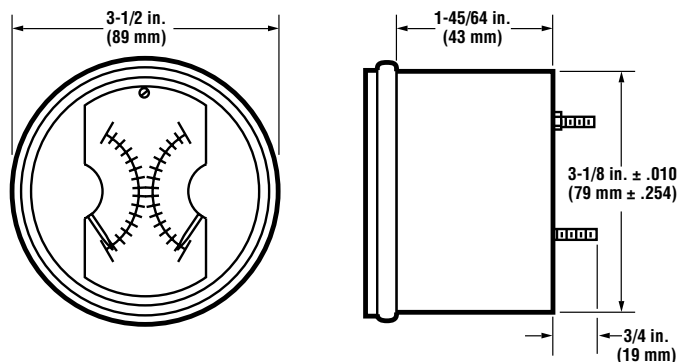

10705147 (00-00-0956)

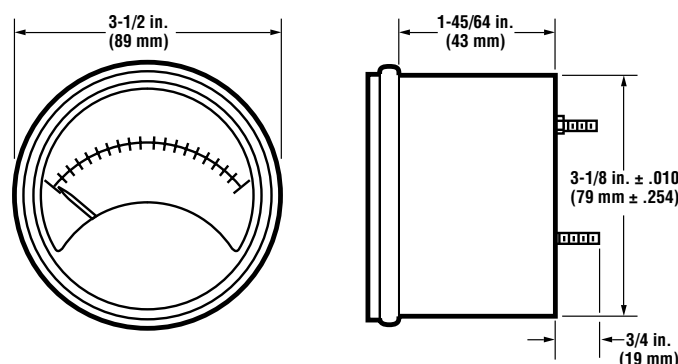

# INSTALLATION

**IMPORTANT: REMOVE SHUNT WIRE FROM INSTRUMENT TERMINALS BEFORE CONNECTING LEAD WIRE.**

## Instrument Installation

The pyrometer instrument should be mounted securely to minimize vibration. Locate in best viewing position. If lamp is removed during installation, lamp hole should be plugged or taped over to prevent dirt or metal particles from contaminating the movement.

## Thermocouple Installation

Various thread mounting adaptors are available. i.e. 1/4 NPT, 3/8 NPT and 1/2 NPT. If not specified, 3/8 NPT will be supplied.

Location will vary depending on application and engine (right). On turbo charged engines, when possible thermocouple should be installed in manifold before the turbocharger. This will give the highest temperature indication and the best response time. Murphy thermocouples are designed to tolerate this location safely. If mounting pre-turbo is not possible a lower temperature of 150 to 200°F (66 to 93°C) will result when mounting after the turbo.

For non-turbo engines, thermocouple may be installed in the manifold before or just after the exhaust pipe flange, as is convenient.

Connecting terminals have staggered lengths to insure polarity, plus color match to extension wire. A plastic heat shrinkable tube is supplied with the thermocouple and should be placed over the terminals after connection is made with the extension wire and heat shrunk in place for insulation.

## Extension Wire (00-00-0817)

Standard length is 14 ft. (4.27 m). When other length required, 2-conductor 18 AWG (1.0 mm<sup>2</sup>) or larger solid copper may be added between extension wire and instrument for up to 100 ft. (30.48 m) lengths. When installing the extension wire, care should be taken to route away from exhaust system and chafing areas, secure with tie wraps to prevent wire movement. Terminal connections to pyrometer are designed to insure correct polarity.

## Warranty

A limited warranty on materials and workmanship is given with this FW Murphy product. A copy of the warranty may be viewed or printed by going to [www.fwmurphy.com/support/warranty.htm](http://www.fwmurphy.com/support/warranty.htm)

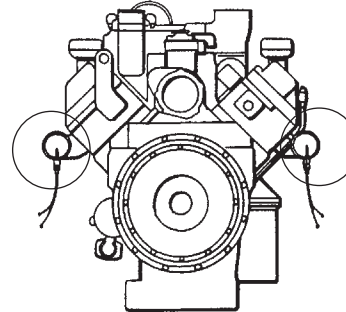

8 Cylinder "V" Type

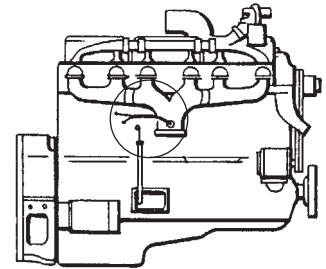

Inline 6 Cylinder Naturally Aspirated

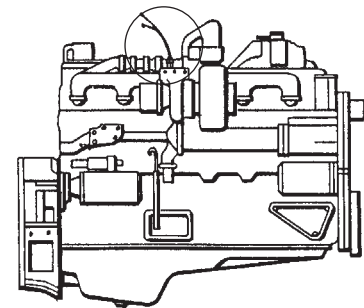

Inline 6 Cylinder Turbocharged

# WIRING DIAGRAMS

10705147 (00-00-0956) Single Port

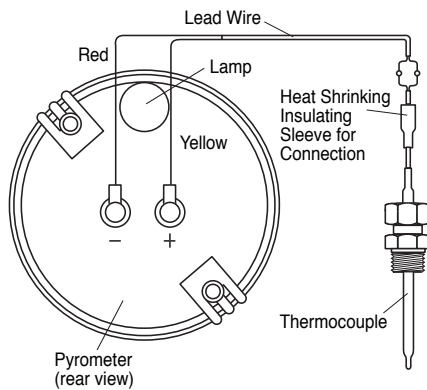

10705146 (00-00-0819) Dual Port

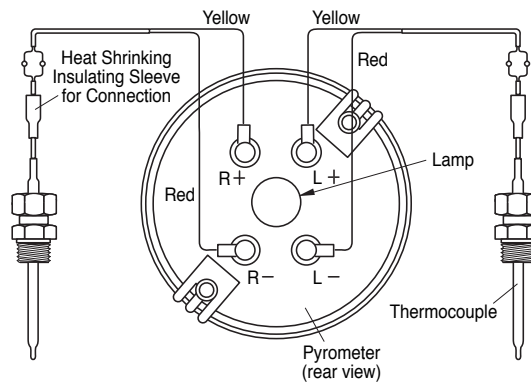

Call MurCal To Place Your Order



ISO 9001 REGISTERED

